

TP 160 PTO

Wood chipper for mounting onto a tractor.

Elegant and efficient wood chipper with hydraulic intake for chipping of branches of up to 160 mm in diameter. The integrated hydraulic system and the 2 horizontal cylinders ensure a strong and problem-free intake.

TP 160 is a disc cutter where the wood is cut at an angle of 90 degrees. The heart of the machine is the two knives and the two anvils that ensure efficient wood chipping and a nice uniform chip quality.

The new design, increased capacity and improved service conditions make the TP 160 an attractive wood chipper and show that even a small machine can be used professionally.

TP 160 PTO can be equipped with stress control system TP PILOT and is recommended for use with a tractor under 36 kW/50 hk

Standard on TP 160 PTO

- Speed-up gear on the PTO model
- Simple knife fitting without adjustment
- Integrated hydraulic system
- Two knives
- Two anvils in Hardox material
- Two hydraulically powered feed rollers
- Powerful spring to hold against moving cylinder
- Turnable ejector tube
- Wipers to avoid accumulation of material at the feed rollers and in the rotor house
- Hydraulic adjustment of the cylinder speed
- Rotor lock to secure rotor disc at knife change
- Operation bar for start/stop/reverse of the feed rollers
- All wearing parts can be changed with standard tools
- Detailed manual with spare parts catalogue

New initiatives:

- New elegant design
- 10 mm chip size => higher capacity
- Unencumbered access to anvil
- Improved chip quality because of the cylinders location in relation to the rotor house
- More powerful intake
- Reinforced s-point linkage
- Tow-bar for wagon (as accessory)



TP 100

TP 130

TP 160

TP 200

TP 250

TP 230

TP 270

TP 280

TP 400

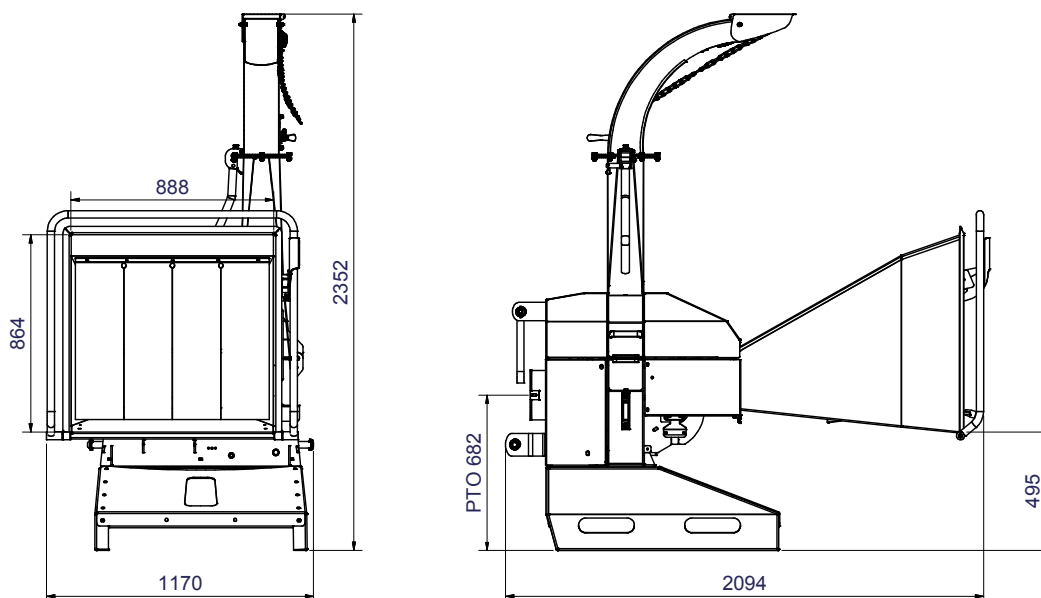

TECHNICAL DATA

Max. wood diameter	160 mm
Opening of funnel	H x B = 160 x 220 mm
Operation	Return/forward/stop of feed rollers through operating bar (yellow)
chipping principle	Disc
Rotor disc - weight in kg	85
Feeding angle	Parallel to driving direction
Feed	2 hydraulic feed rollers. spring compressed of 1 spring in 8 mm
Feed rollers	Horizontal, upper feed roller with tooth discs
Number of knives	2 pcs.
Chip length	4 - 10 mm (hydraulic ajustable)
Counter steel/anvil	1 horizontal and 1 vertical in Hardox material
Power required	22-59 kW (30-80 hk)
PTO rpm	540 rpm/min
PTO shaft	Walterscheid 2300 series with freewheel, length = 560 mm
Three-point linkage	Kategori 1+2
Chip capacity	5-12 m ³ /hour
Weight	585 kg

ACCESSORIES

Stress control system	Monitors the rpm on the rotor disc to protect the engine of the tractor
Sliverbreakers	TYPE A (with 4 fingers)
Extended ejector spout	500 mm vertical - 1.000 mm horizontal
Light bar	Light bar with a complete set of rear lights
Tool kit	contains tools for daily service and maintenance
Tow bar	Max. prodsøje pressure = 500kg