

TP 160 MOBILE

Wood chipper on trailer with own motor.

Elegant and efficient wood chipper with hydraulic intake for chipping of branches of up to 160 mm in diameter. The integrated hydraulic system and the 2 horizontal feed rollers ensure a strong and problem-free intake.

TP 160 is a disc chipper where the wood is cut at an angle of 90 degrees. The heart of the machine is the two knives and the two anvils that ensure efficient wood chipping and a perfect uniform chip quality.

The new design, increased capacity and improved service conditions make the TP 160 an attractive wood chipper and show that even a small machine can be used professionally.

Standard on TP 160 MOBILE

- Integrated hydraulic system
- Two knives
- Two anvils in Raex 400
- Simple knife fitting without adjustment
- Two hydraulically powered intake cylinders
- Powerful spring to hold against moving cylinder
- Turnable ejector tube
- Wipers to avoid accumulation of material by the feed rollers and in the rotor house
- Hydraulic adjustment of the feed rollers
- Rotor lock to secure rotor disc at knife change
- Operation bar for start/stop/reverse of the feed rollers
- TP PILOT stress control system with hour counter
- All wearing parts can be changed with standard tools
- Extensive manual with spare parts catalogue

New initiatives:

- New elegant design
- 10 mm chip size
- Unencumbered access to anvil
- Improved chip quality because of the cylinders location in relation to the rotor house
- More powerful intake
- New automatic coupling system
- Easy access to motor room



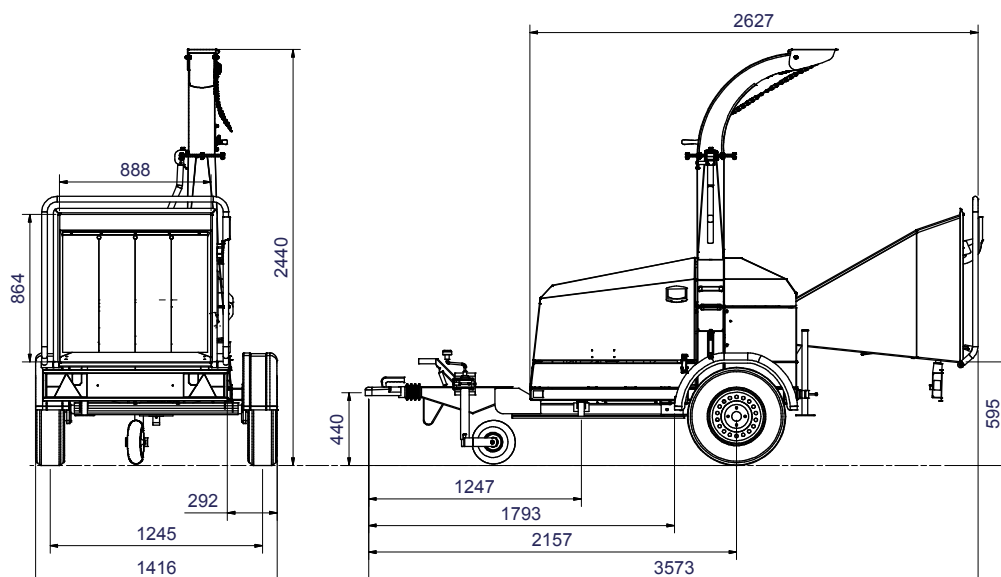

TECHNICAL DATA

Max wood diameter	160 mm
Max opening at feed rollers	H x B = 160 x 220 mm
Operation	Return/forward/Stop of feed rollers through operating bar (yellow)
Chipper principle	Disc
cutting angle	90°
Feeding angle	Parallel to driving direction
In feed	2 hydraulic feed rollers. spring compressed of 1 spring 8mm
Feed rollers	Horisontal - upper feed roller with tooth discs
Rotor disc - diameter	660 mm
Rotor disc - Weight in kg	85
Number of knives	2 pcs.
Chip length	Up to 10 mm (hydraulic ajustable)
Anvil/counter steel	1 horizontal and 1 vertical
Motor	Lombardini 4 cyl. 26 kW/35 hp
Transmission	Automatic coupling system
Indicator and stop of motor by:	Too low oil pressure and too high temperature on cooling system
Stress control - TP PILOT	Including hour counter
Fuel consumption	3,5 liter/hour (Experience number)
Tank volume	20 liter
Trailer	One axlet trailer (80 km/h) with drawbar and breaks, galvanized
Chip capacity	5-10 m³/hour
Weight	With Lombardini motor 822 kg

ACCESSORIES

Extended ejector spout	500 mm vertical - 1.000 mm horisontal
Lock	Lock which can be mounted over the trailer hitch
Tool set	Includes tools for daily service and maintenance
Sliver breakers	Type A with 4 fingers