

# TP 150 MOBILE

Small, compact and effective wood chipper with hydraulic feeding for chipping branches up to 150 mm in diameter. The integrated hydraulics system controls the two horizontal rollers which ensure a strong and problem free feeding.

TP 150 is a disc chipper where the wood is cut at a 90 degree angle. The heart of the machine is the two knives and the two anvils. The wood chipping is done with great efficiency - and with a nice, uniform chip quality.

## Standard on TP 150

- Integrated hydraulics system
- Two knives
- Two anvils in Hardox 400
- Two hydraulically powered feed rollers
- Powerful tension spring on moving rollers
- Revolving ejector spout
- Wipers to ensure against accumulation of material at feed rollers and rotor housing
- Hydraulic adjustment of the roller speed and thereby the chip size
- Rotor lock for securing the rotor disc when changing knives
- Operating bar start/stop/reversing of the feed rollers
- PTO shaft for TP 150 PTO
- Stress control system, TP PILOT



TP 100

**TP 150**

TP 200

TP 250

TP 230

TP 270

TP 280

TP 400

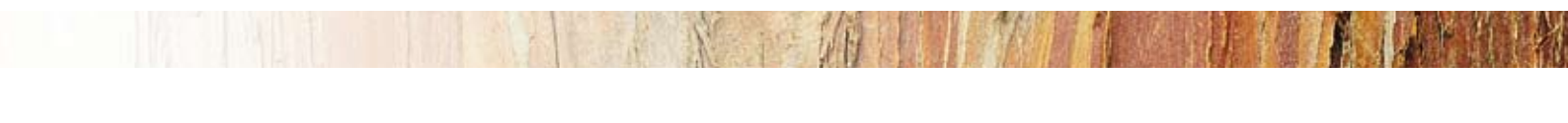

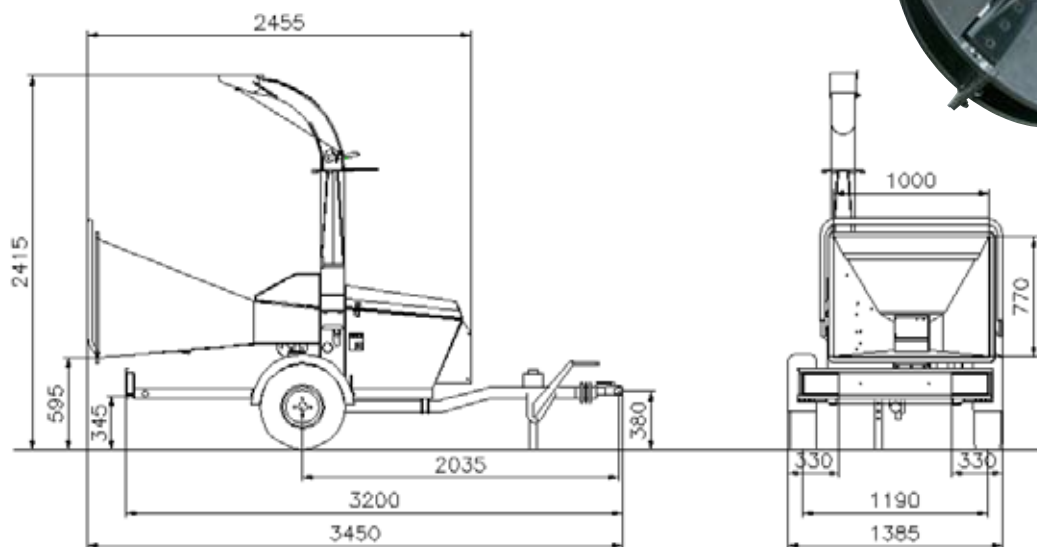

## TECHNICAL DATA

Max wood diameter	150 mm
Max opening	H x W = 150 x 210 mm
Operation	Return/forward/stop of feed rollers through operating bar (yellow)
Chipper principle	Disc
Chipping angle	90°
In feed angle	Parallel to driving direction
In feed	2 hydraulic feed rollers, spring compressed of 1 spring 8 mm
Feed rollers	Horizontal
Rotordisc - diameter	660 mm
Rotordisc - Weight in kg	85
Number of knives	2 pcs.
Chip length	0 - 8 mm (hydraulic ajustable)
Anvil/Counter steel	1 horizontal and 1 vertical
Engine	Lombardini 3 cyl. watercooled diesel with 27 hk
Transmission	Clutch between V-belt and engine - 2 v-belts between engine and rotor
Indicator and stop of engine	Too low oil pressure and too high temperature on coolingsystem
Stress Control - TP PILOT	Including hour counter
Fuel consumption	3 liter/hour (experience number)
Tank volume	24 liter
Trailer	One axlet trailer (80 km/h) with drawbar and breakes, galvanized
Chip capacity	3-4 m <sup>3</sup> /hour (Experience numbers by manuel operation)
Weight	800 kg

## EXTRA EQUIPMENT

Extended ejector spout	500 mm vertical - 1.000 mm horizontal
Lock	Lock which can be mounted over the trailers hitch
Tool kit	Includes tools for daily service and maintenance