



TP 130 PTO

Wood chipper for tractor

The characteristic of the new wood chipper is the wish to optimize on price without compromising on quality. TP 130 has one hydraulic driven feed roller which is manufactured with tooth feeders made from wear steel which gives a strong and aggressive infeed when the wood is fed through the hopper and directly to the knives. The chips that are produced are 8 mm long and very uniform as the wood is cut at an angle of 90 degrees.

In terms of safety the machine complies with current regulations in the EU. The wood chipper is equipped with an operation bar for controlling the feed roller. With the operation bar it is possible for the operator to start and stop as well as reverse of the feed roller.

Standard on TP 130 PTO

- Integrated hydraulic system
- Two knives
- Two counter steels in Raex 400
- Simple knife fitting without adjustment
- One hydraulic driven feed roller
- Turnable ejector spout
- Wipers to avoid accumulation of material by the feed rollers and the rotor housing
- Rotor lock to secure rotor disc when changing knives
- Operation bar for start/stop/reverse of feed roller
- Adjustable foot in 2 positions
- PTO linkage
- Extensive manual with spare parts catalogue
- All wearing parts can be changed with standard tools



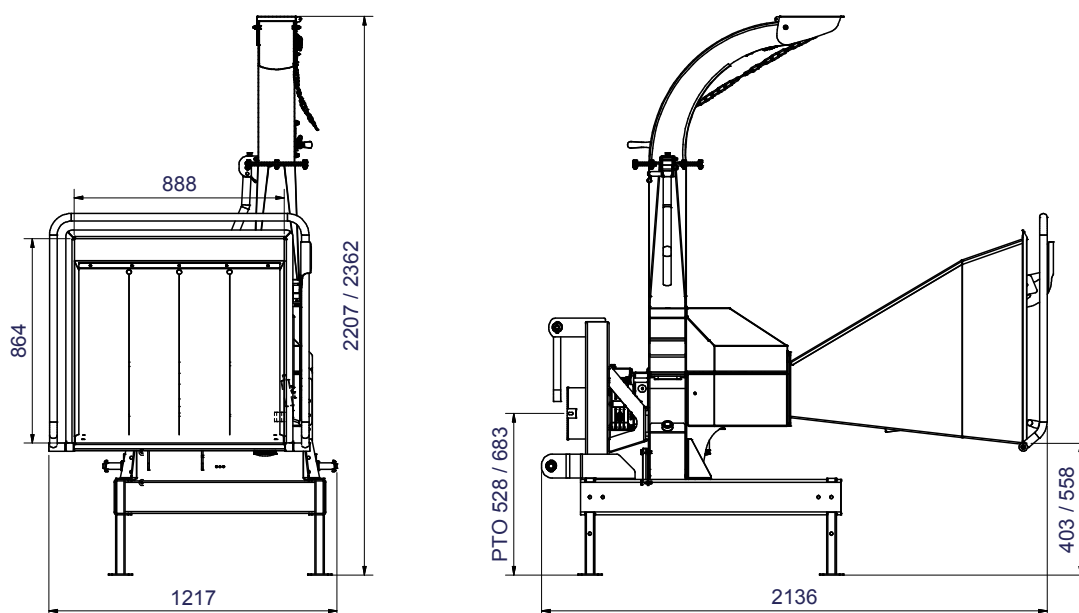

TECHNICAL DATA

Max. wood diameter	130 mm
Max. opening at feed roller	H x B = 130 x 220 mm
Operation	Return/forward/stop of feed roller through operation bar (yellow)
Chipper principle	disc
Rotor disc - weight in kg	85
Feeding angle	Parallel to driving direction
In feed	1 hydraulic driven feed roller, spring compressed of 18 mm spring
Feed roller	Horizontal
Number of knives	2 pcs.
Chip length	8 mm
Counter steel	1 horizontal and 1 vertical
Required power	18-45 kW (25-60 hp)
PTO	540 rpm./min
PTO shaft	Walterscheid with free wheel, length = 560 mm
3-point linkage	Kategorier 1+2
Chip capacity	3-10 m ³ /hour
Weight	502 kg without PTO

ACCESSORIES

Stress control system TP PILOT	Monitors the rpm on the rotor disc to protect the engine of the tractor
Sliverbreakers	TYPE A (with 4 fingers)
Guard in rotor housing	Recommended if uniform chips are required
Extended ejector spout	500 mm vertical - 1.000 mm horizontal
Light bar	Light bar with a complete set of rear lights
Tools set	Contains tools for daily service and maintenance